



The QR code of users manual & after-sales service manual

The practical appearance and function of the product will not be completely consistent with the description of this manual because of technology upgrade and firmware update, So the actual appearance is based on real object. Please download the update manual for the latest performance instruction and security guide by visiting our official website or communicate with other users on our official website BBS.



Light Bee S
Users Manual & After-Sales Service Manual

www.sur-ron.com

Please do read the manual carefully before riding, and do not ride the bike before you fully understand its performance. And please properly keep this manual.

TO Every SUR-RON rider.
Thanks for your trust and love.



WARNING

To protect against battery and motor failure, personal injury, deep fording riding is forbidden!

•Please wear safety helmet and obey the traffic rules during the riding!

•It's prohibited to ride the bike with unlocked battery cover!

•Please remove the battery before you wash the bike, and do not use high-pressure water gun to flush the battery or other electrical parts!

1 Safety Instruction-----	01
2 Functional diagram-----	05
3 Quick Assembling Guide-----	08
4 Preparation for riding-----	12
5 Learning to ride-----	13
6 Operating Instructions-----	18
7 About Charging-----	20
8 Specifications-----	23
9 Other Statements-----	26
Attachment: electrical diagram of this bike-----	27
10 Failure phenomena and troubleshooting methods-----	28
11 Maintenance guide-----	30
12 User's own periodic maintenance table-----	35
13 Periodic Maintenance Record Card & Warranty Record Card-----	36

The picture is for reference only,
The actual appearance is based on the real object.

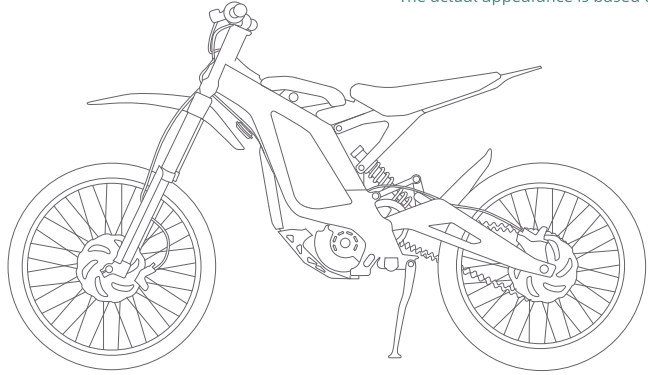

01 Enjoy the riding of Light Bee S

For your safety, please do read the manual carefully before riding and properly keep a this manual. Please do not ride the bike before you fully understand its performance. All pictures of this manual are for reference only, so actual appearance is based on the real object.

1 Safety Instruction

- You have the obligation to learn about local laws of electric bike riding, and to obey the local laws and local traffic rules.
- Before the first riding, please do this manual, and then, do some practice riding on a safe ground to fully grasp the riding skills, familiar with the construction of the bike.
- Please do not lend this bike to the people, who do not know how to ride it, to avoid any injuries happen. And make sure that the rider (the owner or any other people who lend the bike) has read this manual. It is your responsibility to ensure the safety of new riders. Don't leave new riders alone to ride this bike until they fully learned about the basic operation.

- Please wear qualified helmet and other protective equipment properly for riding.
- Please do not park this bike on the evacuation staircases and walkways or in front of building foyers and exits.
- Please do not park and charge this bike in the residential building. This bike should be kept away from combustible materials as you charge the battery, and the charging time should not be too long.
- This bike is limited to load one person, so don't carry another passenger or any other stuff.
- Please dress colorful clothes with non-open cuffs and good flexibility but not tight for you when you ride the bike. It's dangerous to wear slippers or high-heeled shoes to ride the bike.
- Please don't park (or ride) this bike in the rain for a long time to protect the electronic parts of this bike to be damaged.
- Washing precautions: remove the battery before wash the bike. Do not flush the battery or other electronic parts with high-pressure washer.
- It's prohibited to immerse the battery in water (if the appearance of the battery is damaged, the waterproof performance of the battery will be damaged.). The height of fording can't be higher than the wheel's radius, or that the water will go into the battery will result in internal short circuit, battery permanent failure, even explode. Under the above circumstances, it is forbidden to charge the bike or take out the battery to charge, otherwise that will cause the battery fire, combustion and explosion risk.
- For your safety, do not privately modify this bike, if you need to replace some parts, please contact the after-sales service.
- You must stop riding this bike immediately after hearing the abnormal noise or alarm from this bike, and then you need to contact the after-sales service to obtain the instruction and maintenance service.

Riding environment requirements:

- Do not ride in bad weather or extreme fatigue. The slippery ground in rainy and snowy days will be dangerous for riding because of extended braking distance demand. In the days, please do not ride the bike outside.
- Please avoid riding this bike with high speed and be careful for steering in a complex road environment, or it will bruise yourself on account of riding out of control.

- Please avoid riding in heavy rainy days or on the fording road, because it will damage the motor or the controller when the waterline higher than the wheel's radius. You can ride in rainy and snowy days but long time deep fording is prohibited, and the fording depth can't exceed 20cm.

- The operating temperature of SUR-RON electric bike is -10~45°C, and the storage temperature is -10~50°C. Recommended Storage Temperature is 10~30°C. Do not store or ride our bikes outside the temperature range.

Rider requirements: (the following persons should not ride SUR-RON electric bike)

I . .Pregnant women or these persons who unable to engage in strenuous physical activity because of illness.

II . Under the influence of alcohol or drugs

III. These persons whose weight is in excess of load limitation. (please refer to p23 "model parameter table")

03

Pre-inspection before riding:

- Please check whether the tires have cracks and abnormal wears or not, and check whether the tires are embedded with any objects such as nails, stones, and glass.
- Please check whether the tire pressure is 32.6 psi (225 kPa) to ensure you can normally ride this bike.
- Please check whether the screws of wheel axle are torqued tightly.
- Please check whether the wheels and handlebar all are well fixed: you must ensure the handlebar and wheels are not loose and work well.
- Please check the status of power supply circuit, lighting circuit and so on are going well.
- Please check the function of front and rear brake system are going well.
- Please keep the battery's power is enough for riding.
- Please check whether the spokes of wheels are torqued tightly. (1.5N·m-2.5N·m)
- The throttle is smooth without jam and returns to position quickly.
- Please check the tension of the chain: the tension space of the chain is 1-2cm. we suggest that you

clean the sediment of the chain and lubricate the chain, if the chain was stuck.

- Please check the belt: you can apply mute oil on the belt or clean the impurity of the belt after hearing abnormal sound.
- Please check whether the inner tubes of the front shock absorber are clean.
- Please check whether the inner tube of the rear shock absorber is clean.
- Please check whether the front and rear brake all work well, and the brake cables are intact.

Riding requirement:

- This bike is for single person riding, please do not carry any other people. Overload is prohibited.
- Control feeling of loaded riding is different from single riding. If you carry any stuff when you ride the bike, will seriously affect the control and leads to an accident. This bike is limited by the load of one person, so don't carry another one.
- To avoid distraction, do not use mobile phones, cameras, headphones, earplugs, etc when you ride.
- Please slow down and avoid pedestrians, bicycles and motor vehicles when you approach or pass an intersection, motorway, bend, gate, etc.
- Please stop riding and contact with the after-sales service immediately when you feel the bike is abnormal. You couldn't ride the bike until you found these problems and repaired it.

Other requirement:

- Please park this bike on a flat road and turn off the power. Otherwise, it may lead to slide, and bring slide harm to the people around you and yourself. Don't park this bike on the sloping or soft ground to prevent it from toppling over!
- Please use the special charger of the lithium battery. The charger input voltage is 220V (110V for America). You need to stand this bike before charging it, when the charger or charging port is wet, please stop charging. Do not charge or park this bike in restricted areas. During the charging, please keep away from combustibles, and cut off the power in time after the charging.
- Do not charge the battery below 0°C, otherwise the battery will be damaged. Please wait for recover of the battery temperature before charging.

04

2 Functional diagram

Please identify each part of this bike and familiarize yourself with the structure.

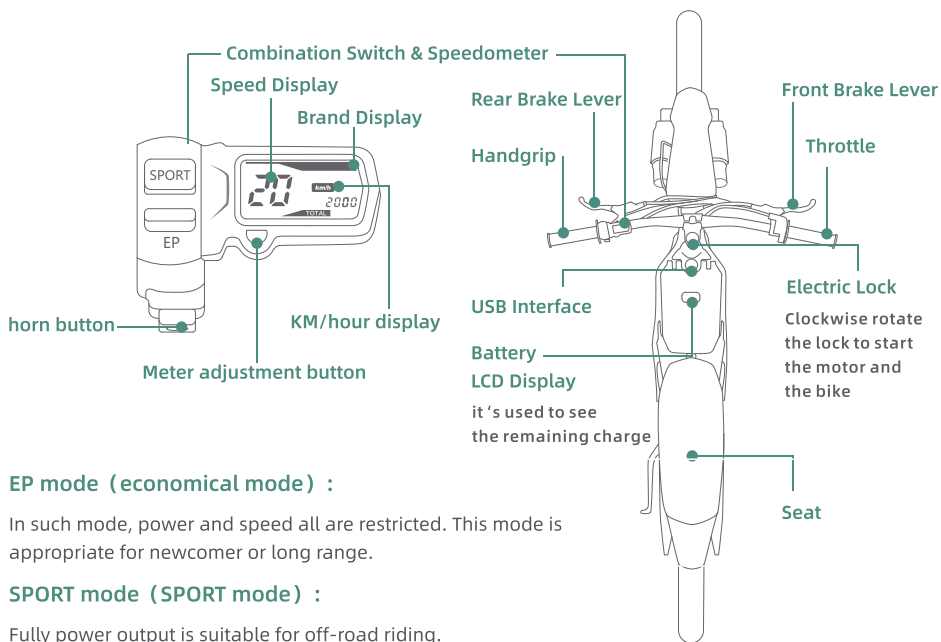

EP mode (economical mode) :

In such mode, power and speed all are restricted. This mode is appropriate for newcomer or long range.

SPORT mode (SPORT mode) :

Fully power output is suitable for off-road riding.

Speedometer adjustment button:

- Clicking it to switch between the current speed and the total mileage or the maximum speed and the mileage.
- Long press the button to clear the data of the maximum speed and maximum mileage.

The picture is for reference only,
The actual appearance is based on the real object.

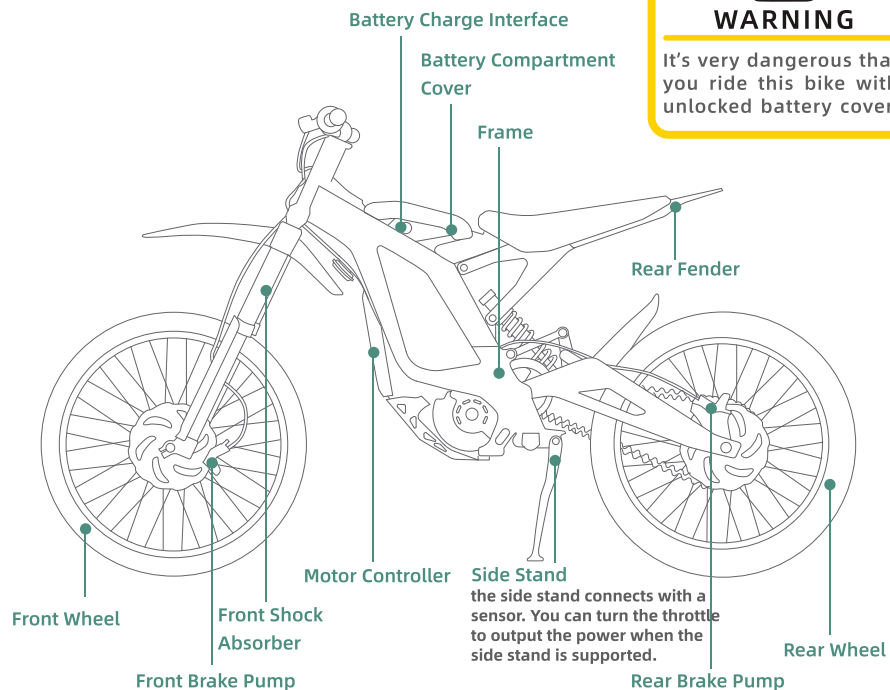

Notice: When the motor or the controller temperature is too high, or the battery is too low, this bike will automatically reduce the power, so that is not a fault.

The picture is for reference only,
The actual appearance is based on the real object.

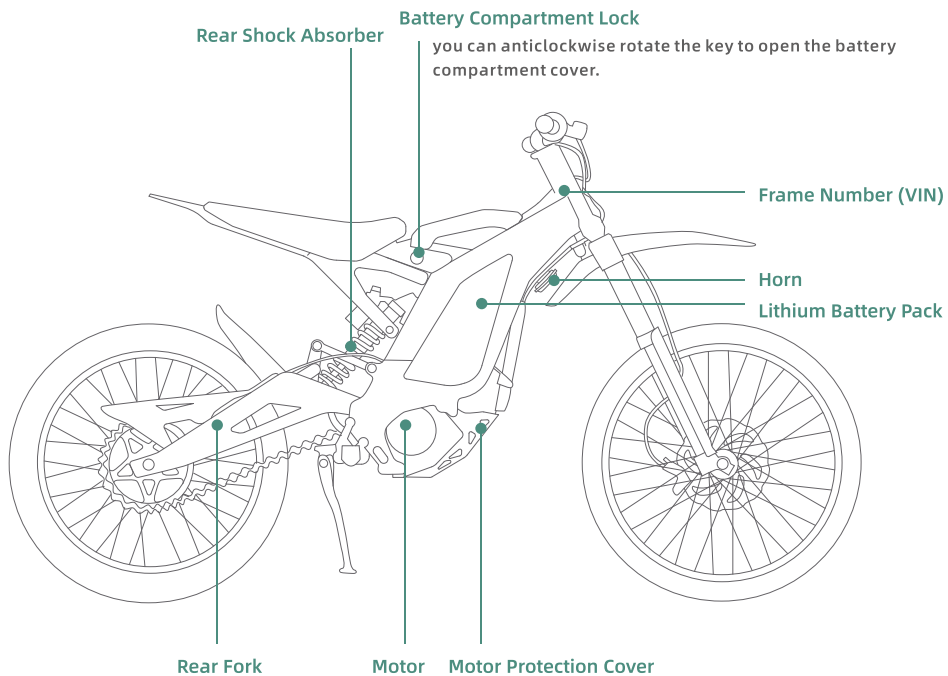

Notice: Please safely keep the unique frame number and motor number of every bike for maintenance, recondition, and service.

3 Quick Assembling Guide

Handlebar Assembly

1.Loosing the 4 locking screws with 4# internal hexagonal wrench and taking the fixing cover down.

* Please do not lose the screw gasket.

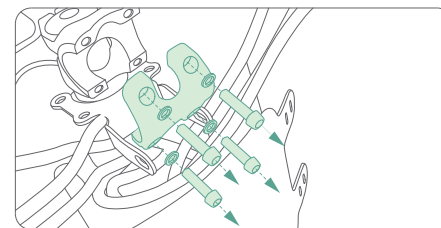

2.Fix the front brake lever and throttle on the handlebar in turn

* Do not tighten them

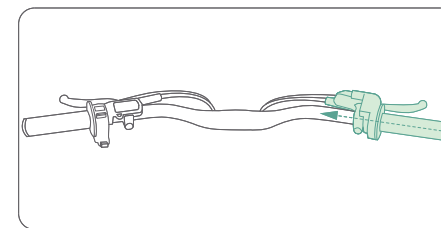

3.Put the handlebar on the handlebar stem, then fixing the handlebar cover and aligning the handlebars to the handlebar stem according to the scale mark.

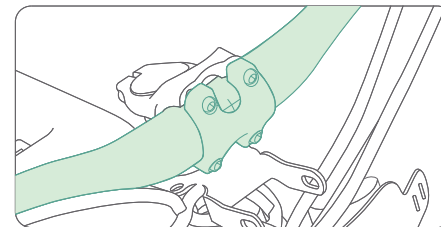

4.Tightening the 4 locking screws with 4# internal hexagonal wrench.

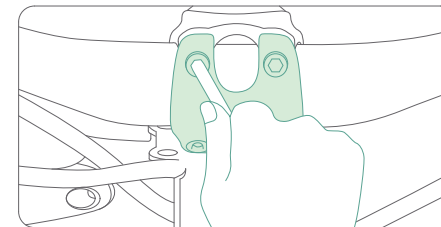

The picture is for reference only,The actual appearance is based on the real object.

Front brake lever

& throttle assembly

1.As shown in the illustration, please adjust the front brake lever and throttle to right angle.

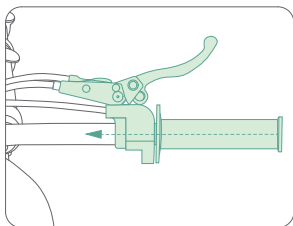

2.Please separately tighten the front brake lever and throttle with 4# internal hexagonal wrench and 5# internal hexagonal wrench.

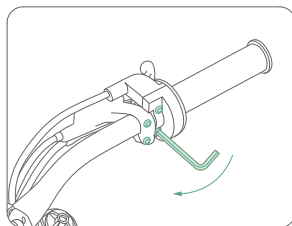

3Please rotate the throttle and check whether the throttle can smoothly return.

* you can check the mount position of the throttle and the direction of the throttle cable ,if it is jammed.

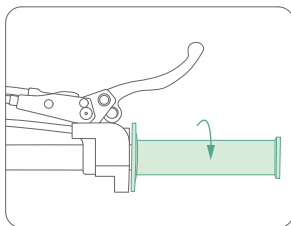

4.Please remove the brake clipper clamping block, and place the front wheel on the wheel mounting position of front shock absorber.

*Please pay attention to the brake clipper as you mount the front wheel.

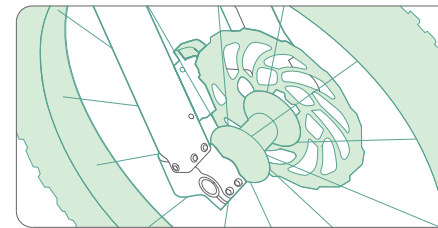
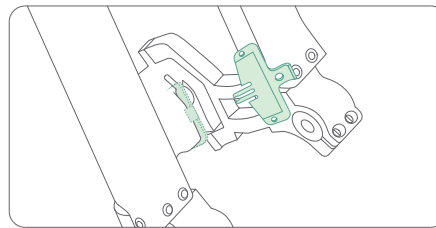

09

Front Wheel

Assembly

1.Loosening the 4 screws below front shock absorber with 4# internal hexagonal wrench.

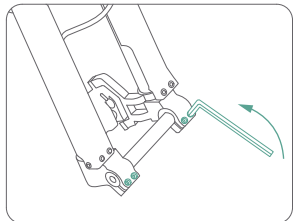

2.Loosening the locking screw located on either side of the front wheel axle with 8# internal hexagonal wrench. Please lightly knock the axle to take it out.

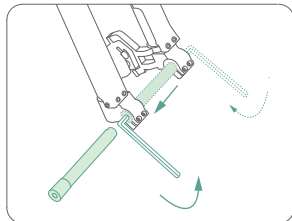

3.Please separately mount the front wheel bushing on either side of the front wheel axle.

* Don't crush the seal ring.

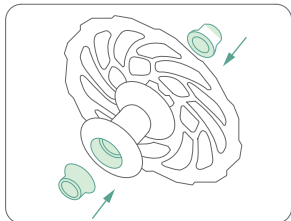

5.Mounting the axle, and making it through the front wheel axle and the front shock absorber in turn.

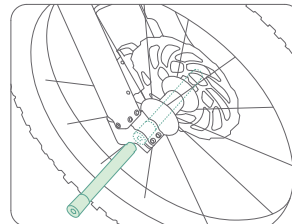

6.Tightening the nuts on either side of the front wheel axle with 8# internal hexagonal wrench, and checking whether they are well fixed.

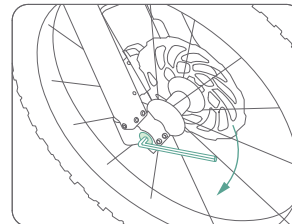

7. Tightening the 4 screws below front shock absorber with 4# internal hexagonal wrench.

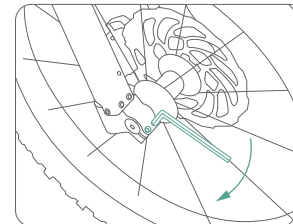

The picture is for reference only, The actual appearance is based on the real object.

10

Front Fender Assembly

Removing the 3 bolts located on the position of below illustration shows.

Mounting front fender, and then tightening the bolts with 4# internal hexagonal, finally check whether the front fender is tightly fixed.

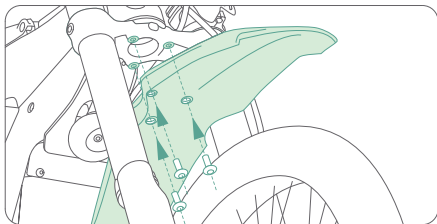

11

Battery Assembly

* Precondition: the bike is turned off.

1. Opening the battery box and take out the battery. Please anticlockwise rotate the key to open the battery compartment cover. Ensuring to turn off the left side of circuit breaker.

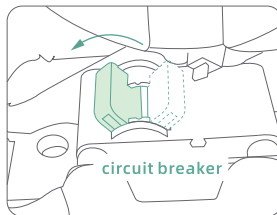
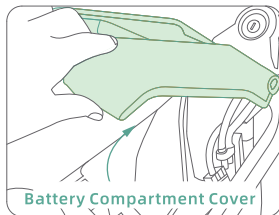
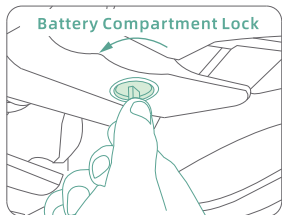

2. Putting the battery into the bike.

* * Direction of battery:
Charging interface towards the left side of this bike

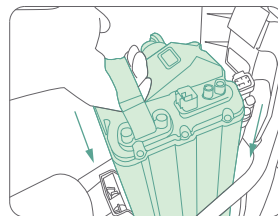

3. Connecting discharge plug and communication plug.

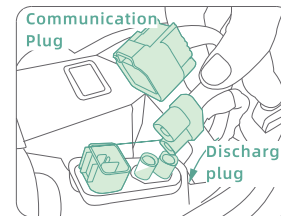

4. Turning on the circuit breaker towards the right, locking the battery compartment cover, and safely keeping your key.

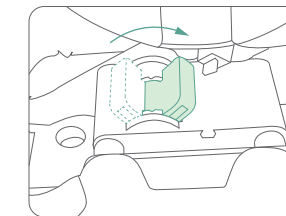

The picture is for reference only, The actual appearance is based on the real object.

4 Preparation for riding

12

Tire Inspection

1. Check whether front tire and rear tire all are intact.

2. The normal tire pressure for both front and rear tires are 225Kpa. Low tire pressure will cause abnormal wear, wheels out of control, slow speed and short mileage. Higher tire pressure will cause the inordinate wear, poor comfort, or even tire burst, and finally will result in potential safety hazards.

1. Please check whether the function is normal for every part of speedometer.

2. Please operate the switch and check if the horn is working properly.

3. Hold the left and right brake levers, and check whether the front and rear brakes work well.

Inspecting the Speedometer, Horn and Brake System.

Handlebar Inspection

Please check whether the handlebar can be well adjusted and reliably fixed.

Shock absorber adjustment

Please adjust front shock absorber and rear shock absorber according to actual condition.

Please consult with after-sales service by dialing the sales-after service number when there is any problem.

The picture is for reference only, The actual appearance is based on the real object.

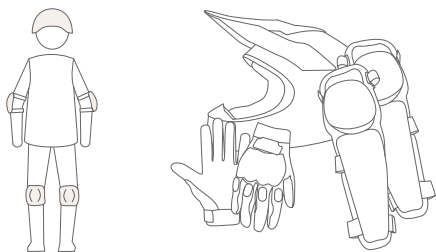

13



WARNING

Please wear the protective off-road helmet and off-road protective equipment properly.

The picture is only for the indication, please completely prepare with safe protection for riding.

Do not lend this bike to newcomer. It's dangerous to ride this bike with one hand or without hands, as well as drunk riding.

5 Learning to ride switch on

1. Using your key to unlock the electric lock.

2. Inspecting whether the speedometer, horn, switch, battery LCD display and brake system all are normal.

3. Before motor start up: Pack up the side stand, slowly and smoothly rotate the throttle towards yourself to start this bike after the rider sit on it steadily.

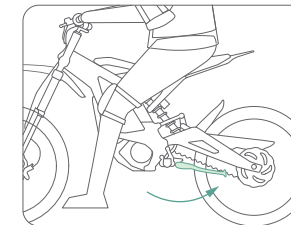
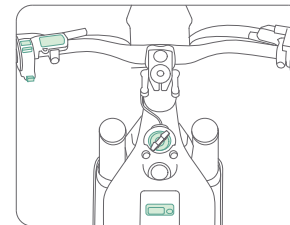
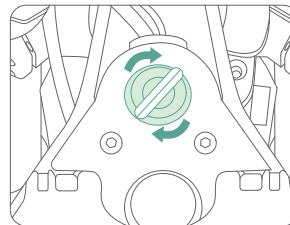

WARNING

To avoid any accidents, it is strictly forbidden to turn the throttle before you sit securely. Side stand can only be used to support this bike. It is forbidden to sit on the seat after putting down the side stand.

The picture is for reference only, The actual appearance is based on the real object.

Speed Adjustment

Adjusting acceleration and deceleration by throttle. Rotating inward means acceleration, and rotation outward means stop acceleration

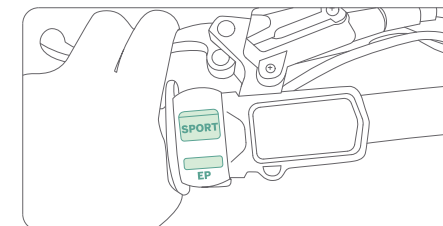
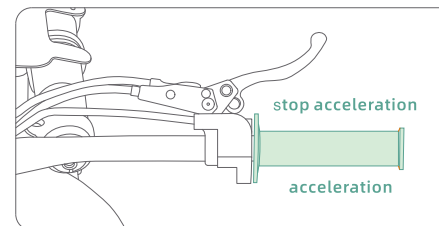

WARNING

Acceleration must be smooth and gentle. Please do not violently accelerate, or it will be dangerous and damage the parts of the bike.

14



WARNING

Please ride this bike in the EP mode for the first time. Don't switch to SPORT mode unless you fully familiar with this bike.

Use of Brakes

Reset the throttle quickly, and hold the left and right brake levers with appropriate force.

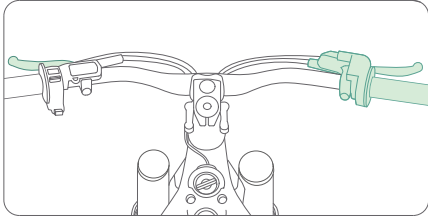

15

If your left hand tightly hold the rear brake lever suddenly while riding, it will cause slip.

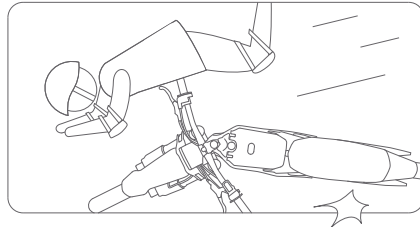
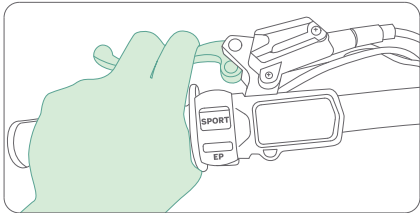

WARNING

Please control the force on brake levers accord to the actual situation, gradually increase the force, and do not suddenly hold the brake levers to be too tight. Otherwise, may cause the wheel-lock and tire-slip, and bring dangers.

Please try to make judgments in advance, and avoid such operations, which may easily cause the side slipping and fall injuries, like sudden braking, wild steering. Especially in rainy and snowy days, the road is slippery, the incorrect usage of brakes will bring dangers.

The picture is for reference only, The actual appearance is based on the real object.

If your right hand tightly hold the front brake lever suddenly while riding, it will lead to turn over.

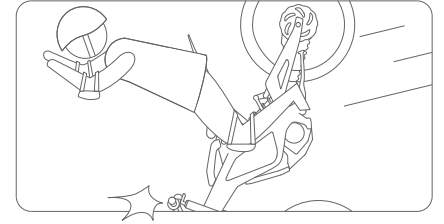
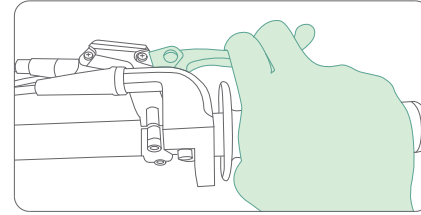

WARNING

It's normal that the electric system will be power down if this bike is toppled over when you ride (It will be restored after you stand up this bike and turn on electric system again). For your safety, you must turn off the power before standing up this bike to protect yourself from the accident which caused by touching the throttle unwittingly.

Parking

Watching out the road environment, and slowly approaching the parking position. Please lock your bike and take the key after completely stopping. Putting down the side stand for support.

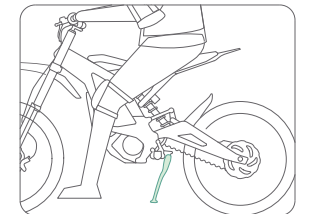
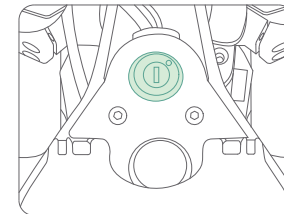
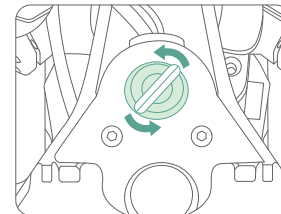

16

**WARNING**

Please turn off the power to protect yourself from the accident which caused by touching the throttle unwittingly when you stop riding and plan to park (but still sit on the seat)

**Notice**

Please avoid any hidden safety hazards! Please don't attempt to try any dangerous actions! Drunken riding is prohibited!



The picture is for reference only, The actual appearance is based on the real object.

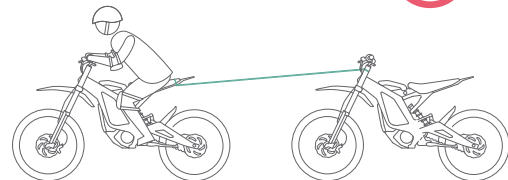

- ⚠ Please do not attach or tow other vehicles while riding.

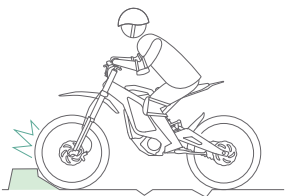

- ⚠ Please be slow and careful when you ride in a complex road environment

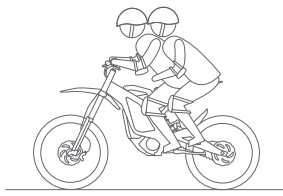

- ⚠ Do not carry any other people or goods.



- ⚠ Do not ride in bad weather or extreme fatigue. In order to protect against battery and motor failures or personal injury, deep fording is forbidden!

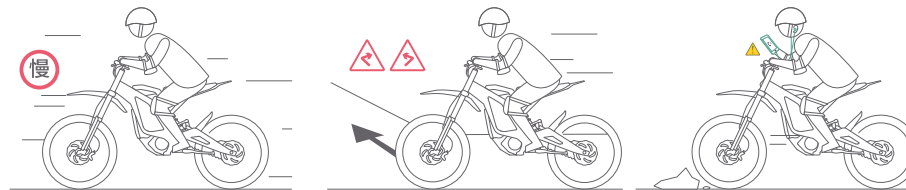

- ⚠ Please ride this bike with double hands, and overspeed riding is prohibited!
- ⚠ Please slow your speed before you sharply turn.
- ⚠ Please do not use mobile phones, cameras, headphones, earplugs, etc when you ride.

6 Operating Instructions

1. Cause of "Power outage" (Electric lock is open, but this bike without any power)

- Brake system black out the electricity. (If you hold the brake lever, it won't output any power that you rotate the throttle.)
- Side stand black out the electricity. (If you put down the side stand to support this bike, it won't output any power that you rotate the throttle.)
- Bike topples over to black out the electricity. (the power will be cut off, if the bike topples over for 3-5 seconds.)
- The temperature of the motor is too high.
- The temperature of the battery is too high.
- The battery runs out.
- The temperature of the Controller is too high.

2. Decrease of Power

- ① When the battery power is less than 15%, the controller will reduce the output power to protect the

battery. There is no way to start Sport mode at this time.

* There exist some errors with the battery LCD display because of the battery characteristic.

② When the battery power is less than 5%, the controller will bring to rest for low-voltage protection. Please charge the battery immediately at that time, otherwise this bike will stall to protect the battery from damages which are caused by over discharge (this perfect self-protecting function can effectively protect the battery cell, but you need to reactivate the battery with the charger when you want to ride this bike. The activation method is in article 6 of fault diagnosis table of after-sales manual on the page 29).

③ The temperature of the Controller is too high. (If the operating temperature of controller is higher than 85°C, this bike will reduce the power and switch to EP mode. If the operating temperature of controller is higher than 100°C, the power output will be cut off.)

④ The temperature of the motor is too high. (If the operating temperature of motor is higher than 130°C, this bike will reduce the power and switch to EP mode. If the operating temperature of motor is higher than 150°C, the power output will be cut off.)

3. About Riding Environment

- Please don't switch to SPORT mode when the battery temperature is below 0°C, because the battery is 80 percent of its normal capacity at that temperature.
- Please don't ride with full power when the battery temperature is higher than 50°C.

4. About Fording

This bike can be ridden on the fording road occasionally (The depth can't exceed 20cm), but cannot be soaked for a long time, especially when the temperature of the motor is too high. After soaking and cooling, the internal air will be compressed to result in the damage which caused by the water that go into the battery through oil seal and cable.

The waterproof grade of every part is as following:

- Battery, Motor: IP65
- Controller: IP67
- Bike connection plugs & Sockets: IP55

7 About Charging

The bike charging

Please plug one side of the charger directly into the charging interface on the left side of vehicle, and then plug another side into the power outlet socket to charge.

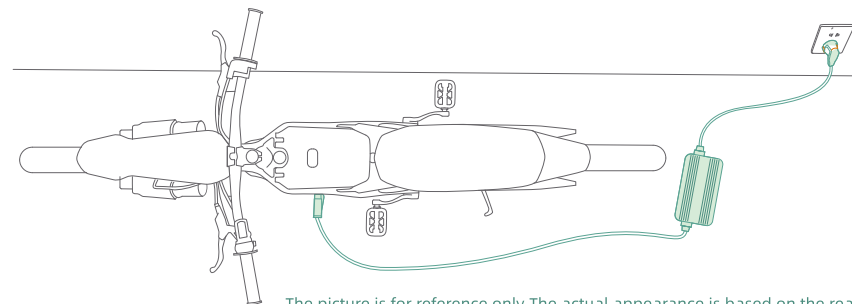

The picture is for reference only, The actual appearance is based on the real object.



WARNING

It's prohibited to charge the battery when the temperature below 0°C. Otherwise, the battery will be damaged. And the battery can be charged after the battery's temperature recovered.

Proper use and maintenance of battery: Used batteries shall not be disassembled without authorization and shall be collected by relevant professional departments.

* If this bike has not been ridden for a long time (more than one month), you have to turn off the circuit breaker or black out the battery wire connection plugs, and fully charge the battery. * Please well cover the battery charging port with waterproof rubber cap when it's not charging.

The portable charging

1. Please check whether the electric lock is well locked. Opening the battery compartment cover and turning off the circuit breaker.

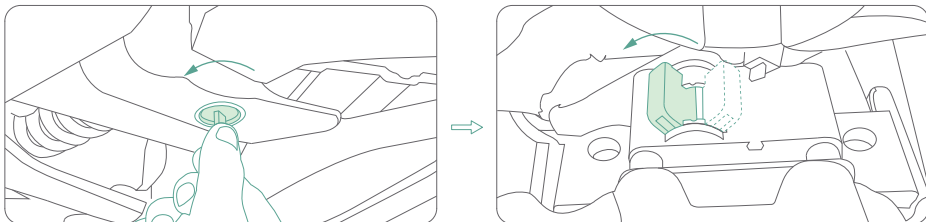

2. Removing the discharge plug and communication plug from the battery.

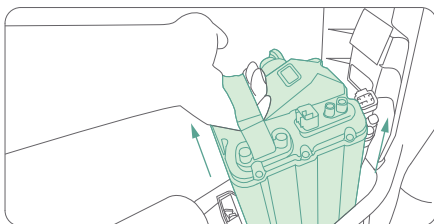

3. Pulling up to take out the battery and close the battery compartment cover.

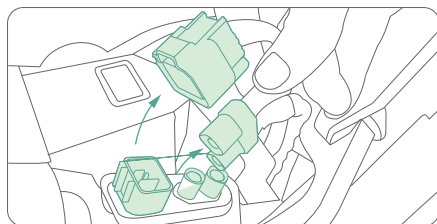

The picture is for reference only, The actual appearance is based on the real object.

4. Please plug one side of the charger directly into the charging interface on the left side of the battery, and then plug another side into the power outlet socket to charge.

*The charger light will flash red to indicate charging. The green light will be always on if the power is full, so please stop charging immediately at that time. Please turn on the

circuit breaker after plugged the battery into the bike.

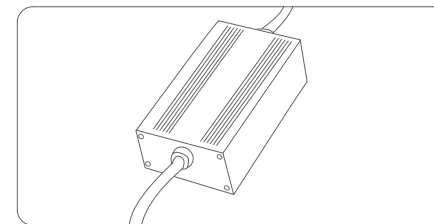
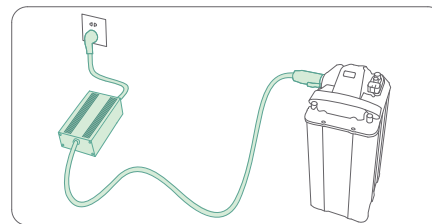

WARNING

Please do not use any other types of charger to charge the battery. If you want to replace a new charger, it should match with the battery model from Sur-Ron. The circuit breaker must be turned off in advance whether you want to take the battery out or plugged the battery in. That plugging or unplugging the battery with power on will affect the life of discharge plug for lithium battery. There is a risk of ignition on the plug when you plug the battery with the circuit breaker turning on, which can easily cause damage to the plug or battery. The charger will automatically turn off after the full charging, but please do not connect the charger to the power grid for a long time, the maximum time is 6 hours.

Precautions for Charging

- While charging, please place the charging device in a safe place where children are not accessible
- It is not allowed to cover the charger with any objects while charging. This charger is for indoor use, therefore, please use it in dry and well-ventilated environment.
- When an odor or high temperature occurs during the charging, or the battery cannot be fully charged for a long time, please stop charging immediately, and sent the charger and battery to the after-sales service center to inspect.

8 Specifications

Performance Index	Item	Light Bee S
Basic Information	Brand	SUR-RON
	Overall Dimensions (length x width x height)	1840X730X1020 mm
	Vehicle Weight (including the battery)	48kg
constraint condition	Max Load	75 kg
Vehicle Parameters	Wheelbase	1250 mm
	Seat Height	800mm
	Minimum Clearance	220mm
	Max. Speed	50km/h
	Max. Power	2.9KW
	Range	65 Km
	IP Rating	Ip65
Battery	Battery Type	Li-Co-Mn 3-element lithium battery
	Capacity	20Ah
	Nominal Voltage	48V
	Battery Over Current Protection Value	70A
	Charging Time	4-5 h

23

Performance Index	Item	Light Bee S
Motor	Motor Type	High speed Brushless DC Motor
	Nominal Power	2Kw
	Nominal Revolving Speed	5000r/min
	Nominal Voltage	48V
Charger	Charger Model	lithium battery charger
	Charger Input Voltage	AC110/220V-50/60Hz
	Charger Output Voltage	58.8V
	Output Current	5A
Controller	Specification and type	48V FOC Sine Wave Controller
	Battery Over Current Protection Value	60A
	Under Voltage protection value	41V
Vehicle Body	Frame Type	Forged double shear beam aluminum alloy frame
	Wheel Assembly Type	Aluminum Alloy Spoke Rim- 17*1.4
	Tire Type	70/100-17 Off-Road Tire
	Primary Transmission System	HTD 8M Belt Transmission (L: 560mm)
	Secondary Transmission System	420 chain transmission with 106links

24

Performance Index	Item	Light Bee S
Vehicle Body	Suspension System	Adjustable single-shoulder front fork with 150mm travel
		Adjustable multi-rod hydraulic spring mono absorber with external air bag and 75mm travel.
	Front Brake	203mm hydraulic disc brake
	Rear Brake	203mm hydraulic disc brake
	Handlebar Type	Ø32 different reducing handlebar
	Communication Port	485 Communication
Other Features	Charging Port of Mobile Phone	USB-5V standard interface with 2400mA

Remarks: The range will be different from different actual riding environment. The range date is collected from the actual test in the following condition: the weight of rider is 75kg, environment temperature is 25°C, speed is 20km/h and so on.

9 Other Statements

- 1.The performance parameter for each model will be different, any changes will be without prior notice.
- 2.To the extent permitted by law, SUR-RON reserves the right to interpret and explain this statement.
- 3.That any unforeseeable or unavoidable risks encountered during riding should be the responsibility of the rider.
- 4.If you want to resell this bike or make a present of it to another people, you should forward this manual together, because it is a part of this bike.

Please consult with our after-sales service when there are any problems. Thank you again for your choice and trust in this bike.

Attachment: electrical diagram of this bike

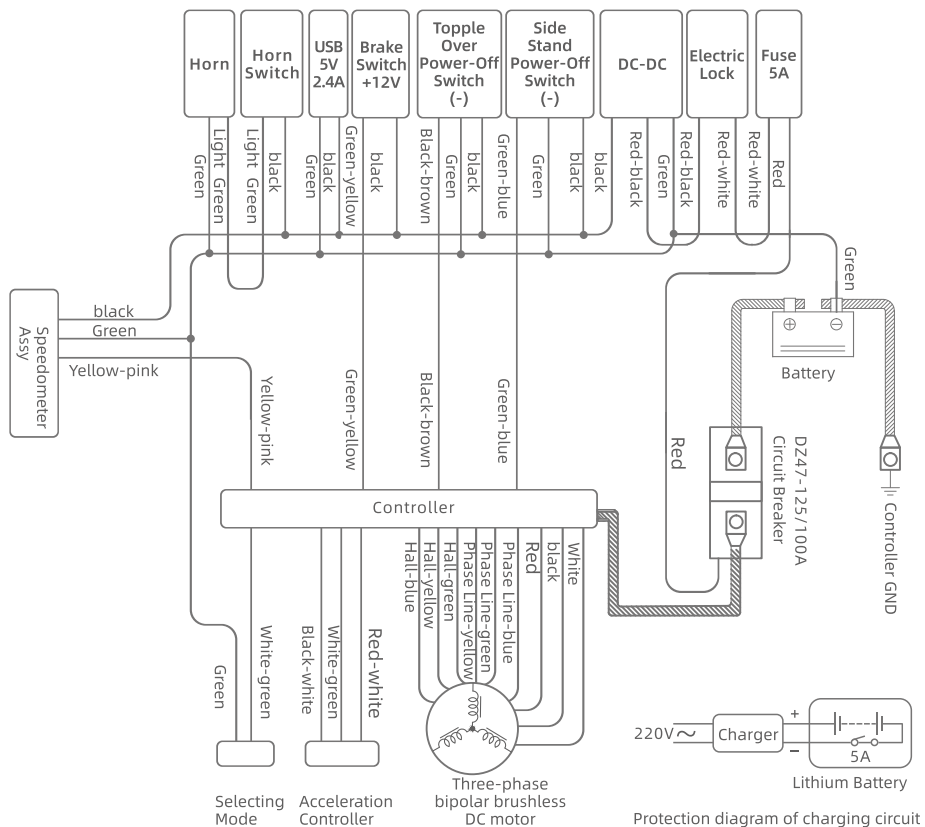

10 Failure phenomena and troubleshooting methods

Item	Failure Cause	Solution
1	The motor does not work after power-on	<ol style="list-style-type: none"> 1.The battery connecting wire is loose 2.Acceleration Controller plug falls off 3.The motor connecting wire is loose or falls off. 4. Brake handles do not return or brake switch sensor is failed.
2	Speed regulation failure and lower top speed	<ol style="list-style-type: none"> 1. Battery Voltage is too low. 2. Fault on throttle
3	Range per charge is insufficient	<ol style="list-style-type: none"> 1.Under-inflation for tire 2.Undercharge or charger failure 3.Improper braking adjustment, excessive running resistance 4.Battery aging or damage 5.A lot of uphill, upwind, frequent acceleration and deceleration, heavy load
4	The charger does not work	<ol style="list-style-type: none"> 1.The charger plug falls off or the connection is loose 2.The plug of battery connection wire falls off or loose.

	Item	Failure Cause	Solution
5	The vehicle makes abnormal noise during the riding	The chain tension is unreasonable.	Adjust the chain tension
6	Plug the charger into the socket of the power supply, it works abnormally, and the battery LCD display shows no power	This bike has not been charged for a long time or improperly preserving the battery result in the battery over discharge protection.	1.Please plug one side of the charger directly into the charging interface on the left side of vehicle, and then plug another side into the socket of the power supply to charge. 2. Pressing the button on the battery LCD display for 1-2s, and then, wait for 10s, then the charger can work normally.
7	Other Fault	1.Any problems, which cannot be inspected or judged by yourself as above directions. 2. Motor, charger, battery, and controller out of service.	Please send this bike to the local after-sales service center. Please do not try to repair the bike with the incorrect solution by yourself. Otherwise, any damages happened, will be out of the warranty

Please read carefully for the above statements, which do not belong to the free warranty coverage.

11 Maintenance guide

In principle, the first inspection should be finished when normally riding to 10-30km. (it can also be interpreted as first maintenance).

Inspection Items

1. Check whether the spokes of front wheel and rear wheel are tight or not.
2. Check whether there exists the clearance between the parts of steering column headset.
3. Check the tension of the chain.
4. Check the tension of the belt. (If the new belt make a slight noise by friction, you can wax the two sides of belt to eliminate the noise, or directly neglect it.)
5. Inspection of shock absorber. Check whether the absorber leak oil, and the damping for compression and rebound is at the right position. (Note: Please don't rotate the knob to the far left or far right during the adjustment.)
6. Check whether every screw of handlebar is tight or not.

Especial notice: In the whole maintenance process, this bike shall not be turned on. It means you can't operate in the starting state of this bike.

Full attention should be paid to safety during inspection

1. Please park the bike on a spacious and flat ground.
2. Check in a safe place, and pay attention to the surrounding environment and conditions
3. When you find any problem by the inspection, please ride the bike after it's repaired. If any problems are too difficult to solve, you can contact the after-sales service or the service center which is appointed by us.

Notice:

1. Both front and rear brake are disc brakes, so you should change the brake pads when it is worn heavily.

2. Please keep clean of the disc brakes during daily riding, and avoid attaching silt or sand on the brake disc for a long time, especially avoid oil contamination.

Inspection of operating parts

1. Please check whether the front or rear shock absorber is bent, deformed, damaged, or not.

Please check whether the front shock absorber has the malfunctions such as damage, loose, oil leakage, etc., and whether any abnormal noise caused by shaking of the handlebar. If the front shock absorber is abnormal, please go to the service center to check for repairs.

2. Inspection of brake

Please check whether the free clearance of the brake handle is within the specified range (15-30mm). If not, please adjust the clearance.

3. Ride the vehicle slowly on the dry and flat road, and try the front and rear brakes respectively, so as to check the braking performance.

4. Inspection of tires

Tires are in touch with the ground for a long time, and stones, glass, nails and other objects on the ground will cause damages to the tires. Therefore, please observe the road carefully when you ride the bike, and avoid the ride on the road where the tires may be damaged. In addition, it's important to check whether there are obvious cracks on the tires, and other damages or wears which are caused by the stones, glass and other abnormal objects.

- 1) Check the air pressure with the tire gauge in the cooling status of the tire.
- 2) Check whether the tires have any cracks, damages, foreign objects, abnormal wear.
- 3) Check whether the rim spokes are loose or not.
- 4) Check the tension of the chain. The chain can move up and down 10-15mm.
- 5) Check the tire tread depth

Please check the wear of the tire tread depth. The tires should be replaced after the tooth on the tire are worn down by 2/3. Please go to after sales service center to do inspection and repair, when there's a noise or shaking of the tire during the riding. It's recommended to set 30N.m for the axle locking

torque, and 40N.m for the rear axle nut locking torque. The front axle screw locking torque is determined by the front fork.

Notice:

1. The tension of belt has been adjusted properly when it deliver out of the factory, please do not change it without permission.
2. Tightly holding the brake lever, and check whether the brake system can work well. If it is not, you can check the brake disc is clean or not. When you still can't repair it, please contact the after-sales service or the appointed service center.

Inspection of Battery

1. Battery Electricity

The sealed 3-element lithium battery is used in this vehicle. Please fully charge the battery before inspection, and then, use the universal meter to measure the voltages of the positive and negative poles. It's normal with the fully charged voltage to be between 58-58.8V.

2. Battery Appearance Inspection

Check whether the appearance of the battery (such as upper sealed cap, under sealed cap, or the battery LCD display) is damaged or not? If it is, the waterproof performance of the battery will be damaged and water will go into the battery. Please contact after-sales service or the service appointed service center to repair.

Notice:

1. Please turn off the bike or circuit breaker (Switch it leftwards) before plug-out or plug-in the battery.
2. If the battery cannot be plug-in, please DO NOT force the operation. Please plug-out the battery to check if there are any foreign objects causing the battery to get stuck.
3. In winter, it is recommended that the storage room for the battery should be higher than 0°C. Please inspect the battery power every month, and check whether the battery level is above 50%.

Battery charging and usage of charger

1. A special charger is used for the lithium battery charging. Please DO NOT use any other types of

charger to charge the battery, so as to prevent any damages of battery or dangers.

2. Check whether the charger input voltage is consistent with the grid voltage.
3. The charger will automatically turn off after the full charging, but please do not connect the charger to the power grid for a long time, the maximum time is 6 hours.
4. To avoid any damages or dangers, it's prohibited to disassemble the battery by yourself.
5. After the battery over discharge protection worked, please reactivate the battery accord to the method, which is shown in article 6 of fault diagnosis table of after-sales manual on the page29.

Usage and maintenance for motor and controller

1. Please check periodically whether the motor screws are loose
2. Please check periodically whether the connection of motor and controller is loose, as well as the status of insulation.
3. Please check periodically whether the fuses are loose.
4. Please do not ride the bike in deep fording, so as to avoid affecting the motor's operation.

Notice:

When the motor or the controller temperature is too high, or the battery is too low, this bike will automatically reduce the power, that is not a fault.



WARNING

The height of fording can't be higher than the wheel's radius, and if you have been riding this bike on the deep fording road for a long time, it's possible to lead the motor to get an interior wet, and cause the failure.

Replacing Fuse

When the bike's speedometer, horns and lights are unable to work well after the circuit breaker and electric lock are turned on, it may be caused by the blown fuse. Please turn off the circuit breaker and then replace the fuse.

1. Open the battery compartment cover, and plug-out the battery. Then please open the fuse box (The box was wound with black insulating tape out of the factory) which is located in front of the circuit breaker.
2. Replace the blown fuse with the spare fuse which is stored in the lid as backup. After that, please close the fuse box, plug-in the battery and then lock the battery compartment cover.

Turn off the circuit breaker

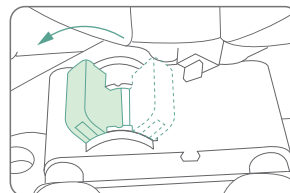

find the white and transparent fuse box

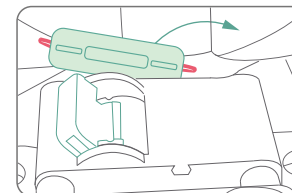

Open the fuse box and replace the fuse

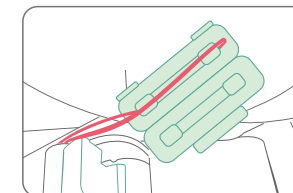

Notice:

1. The fuse must be fixed firmly. If the inserted part of fuse is loose, it may cause a fuse to heat up and thereby will cause other faults and dangers.
2. To replace the fuse, please use the fuse (tubular fuse ,5A) with the corresponding specifications in the specified model. If the fuse that exceeds the specification is used for replacement, it may not be protective.
3. If the fuse is broken immediately after replacement, the bike should be sent to the local after-sales

service center to repair in time.

4. Please avoid the strong water current impact on fuse position.

12 User's own periodic maintenance table

Notice:

Scientific maintenance can greatly extend the service life of the bike, especially the condition of the bike must be thoroughly checked to ensure that all parts of the bike body are working properly after intensely riding or riding on the abnormal road.

User's Own Periodic Maintenance Table	
Maintenance Item	Maintenance Requirements
Front Shock Absorber Front Shock Absorber Maintenance、 Brake oil replacement	Semiannually
Brake Pad Replacement	Thickness: < 0.5mm
Brake Disc Replacement	Between Friction Surface and Brake Pad: < 1.5mm-thick
All of the Axles Replacement	Abnormal sound, loose
Tire Replacement	Tooth Height of New Tire: < 2/3

35

13 Periodic Maintenance Record Card & Warranty Record Card

Periodic Maintenance Record Card		
Maintenance Period	Maintenance Item	Maintenance Man (sign) /Stamp
300km/one month	Inspecting the fasteners of the whole bike, and the tension of the chain and belt (motor/Wheels assembly/brake system/spokes, etc.)	
Riding to 1000km after first maintenance / 3 months	Inspecting the fastens of the safety parts for the whole bike. Inspecting the current and circuit of the main electronic parts. Inspecting the tension of the chain and belt (motor/Wheels assembly/brake system/spokes, etc.)	
2000km/6 months	Inspecting the current and circuit of the main electric parts, brake oil, brake disc, spokes, and the tension of the chain and belt.	

36

Warranty Record Card		
Maintenance date	Warranty Record	Maintenance Man (sign) /Stamp

Warranty Record Card		
Maintenance date	Warranty Record	Maintenance Man (sign) /Stamp